

PELLETIZING & PULVERIZING SYSTEMS >

> UNDERWATER PELLETIZING



Centrifugal dryers

Pellet Processing Systems for the Plastics Industry



Processes and machines and systems made by Gala stand for cost-effectiveness, flexibility, and reliability worldwide. With over six decades of experience and an installed base of currently more than 8,000 pelletizing systems, the company helps its customers achieve the maximum level of profitability.

Gala is the leading manufacturer of centrifugal dryers in the world.

Your benefits

- Door-timed interlocks
- Easy access
- FEA designed
- Clean operation
- Low noise emissions
- Low energy consumption
- Suitable for various applications
- Minimum floor space
- Proven reliability

Centrifugal dryers

Function and Application

Functioning of the Gala systems

The pellets emerging from the pelletizer cutting chamber are carried by the process water through piping to an agglomerate catcher at the inlet of the centrifugal dryer. The agglomerate catcher protects the dryer by removing larger pellet clusters (agglomerates) that may be produced during start-up before they enter the dryer rotor. In dryers with water rates less than 20 m³/h, all the process water is separated inside the rotor section of the dryer. Larger systems are equipped with a pre-dewatering system in which up to 95% of the process water is separated from the pellets. The pellets and residual water flow into the rotor section of the dryer. Both the speed of rotation and the design of the lifters inside the rotor cause the pellets to move between lifters and screens while being conveyed by centrifugal action up the dryer rotor in a helical path. The water is separated through the screens and the pellets are continuously conveyed into the upper section of the dryer, where they are discharged from the resin outlet.

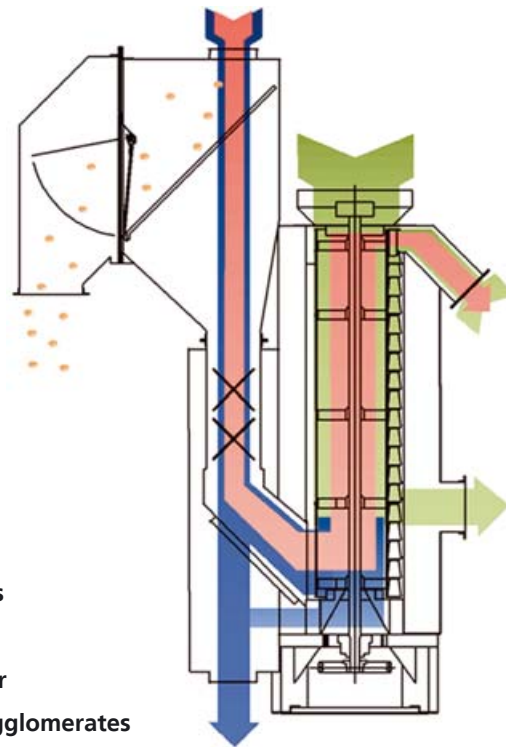

The drying process reduces the residual moisture, depending on the polymer. Final drying is achieved in the upper two-thirds of the screen surface and in the pellet outlet chute of the dryer. Dry countercurrent air flow generated by an external exhaust fan removes the residual surface moisture from the pellets, assisted by the pellets' internal temperature. The exhaust fan produces a slight vacuum which prevents humid air from exiting into the room or condensing in downstream equipment components. The pellets leave the dryer continuously at a residual moisture of 0.05% (LDPE). The length of the water transport line impacts the residual moisture of the pellets and determines the pellet temperature entering the dryer. Additional factors that influence residual moisture are pellet size and shape, pellet surface and hygroscopic characteristics. In some cases, additional cooling, post-drying or classification may be utilized. Materials of construction are offered in 304L Stainless Steel (which is standard), 316L S/S, 2205 duplex S/S and Hastalloy.

Different systems to meet any challenge



Model 4032BF Easy Access Dryer

Easy access system

Production Rate: up to 50,000 kg/h – With the EASY ACCESS series dryer, Gala offers wide doors which permit easy, fast and safe access for internal cleaning and maintenance. All Gala dryers are supplied with door-timed interlocks and/or local power disconnect for operator safety.

- Easy to clean
- Low maintenance
- Large, wide doors
- Door safety interlocks
- Throughput from 500 kg/h up to 50,000 kg/h

Centrifugal dryers

Different systems to meet any challenge

ECLN system

Production Rate: up to 50,000 kg/h – Easy-Clean Low-Noise (ECLN) dryers are particularly easy to service and meet high demands on noise reduction. The ECLN dryer features double walls filled with insulating material. Sound pressure level of ≤ 80 dB(A) is possible. Large, wide doors and larger distances between rotor screens and dryer walls provide easy access to the interior. Integration of the intake and air filter into the resin outlet optimizes countercurrent air flow so less air volume is needed for the drying process.

- Easy to clean
- Low noise
- Insulated housing
- Door safety interlocks
- Throughput up to 50,000 kg/h



Model 48.5 DW ECLN Dryer

High capacity system

Production Rate: up to 100 t/h – Gala has engineered a high capacity centrifugal dryer for continuous processes. Large resin producers are creating the need for higher capacity, continuous operation centrifugal dryers. By utilizing patented processes and innovative equipment designs, Gala has been able to manufacture a single centrifugal dryer with an output of more than 100 metric tons per hour, confirmed by full-scale, customer-witnessed testing, along with improved reliability for continuous long-term use.

- Heavy-duty construction
- Designed for high-capacity, continuous use
- Designed for long-term production
- Door safety interlocks
- Wedgewire screens
- Solid rotor



Model 100 High Capacity Dryer

Self cleaning system

Production Rate: up to 2,500 kg/h – The Self-Cleaning Dryer (SCLN) is designed to achieve a high degree of internal cleaning to minimize downtime. The SCLN dryer does not need to be opened and cleaned manually to prepare the system for a color change in most cases. Thorough cleaning is achieved through a combination of spray nozzles with a powerful water jet, air injection and controlled draining elements. A PLC controller can be used to achieve the highest degree of automation possible and to adapt the cleaning process to the product-specific requirements. Large, wide opening doors and larger distances between rotor screens and dryer walls provide easy and fast access to the interior.

- Easy to clean
- Low noise
- Insulated housing
- Door safety interlocks



Model 2008 Self-Cleaning Dryer

Centrifugal dryers

System components

Careful selection and adaptation of the components of the Gala Centrifugal Dryer ensures optimum results and operator safety.

Agglomerate Catcher

The agglomerate catcher is bolted to the dryer inlet and is designed to catch and discard oversized pellet clusters (agglomerates) before they enter the dryer rotor. Constructed of 304L stainless steel, the agglomerate catcher includes an inclined grate and a gasketed door for access for cleaning. It is manually operated or pneumatically actuated, depending on the size of the dryer and the system requirements. The agglomerate catcher is an option to all Gala centrifugal dryers.



Model 12 Pneumatically Actuated Face Seal Agglomerate Catcher



Model 4 Manually Operated Agglomerate Catcher



Rotor area of a 2016 BF Dryer

Dryer Rotor

The rotor is an integral part of the centrifugal dryer. There are three types of rotors:

Sectional Rotor: modular in design; allows easy replacement of individual rotor components; upgradeable

One-Piece Rotor: designed to be run at higher speeds; solid shaft design; easier shaft replacement

HMA Rotor: designed specifically for hot-melt adhesives or tacky product applications



Pneumatically Actuated Pellet Diverter Valve

Pellet Diverter Valve

The purpose of the pellet diverter valve is to divert product (pellets) from the product outlet of the centrifugal dryer during start-up, for product sampling or for filling containers. The pellet diverter valve bolts to the resin outlet of the dryer and is constructed of 304L stainless steel. It is either manually operated or pneumatically actuated, depending on the size of the dryer and the Customer's line specifications.

Centrifugal dryers

System components

Dryer Screens

The screens are an integral part of the centrifugal dryer and serve to retain the pellets in the rotor area as they travel up the rotor to the resin outlet. The surface moisture escapes through the screen openings and drains back into the process water tank. The type of screen used depends on the product and specifications – from the typical perforated screens used for most applications to special-application screens such as Wedgewire for added strength and durability or Expando and ML (multilayer) screens primarily used for micropellet production.



Perforated Screen used for most dryer applications

Easy Mount (EM) Screens

The perforated dryer screens have been improved to be more operator friendly and easier to assemble and disassemble by using belt straps around the screens. These new Easy Mount (EM) screens are available for any application, up to 16 Series dryer, requiring frequent cleaning, as well as heavy-wear applications, such as underwater pelletizing and drying of glass-fiber-filled compounds. These screens are being utilized in field operations in various applications and have proven to be leak free, fast to install and remove, and easy to clean.



Easy Mount (EM) Screen

Components for special applications

Abrasive Polymers

Wear-resistant components are used in Gala's centrifugal dryers for applications involving products with highly abrasive characteristics. Modular components in heavy-gauge materials of construction and abrasive-resistant coatings on parts in high-wear areas (figure 1) help maximize the efficiency of the dryer and life of the parts when processing these abrasive polymers.

Non-Stick Coating

Most metal components in the dryer can be coated with a durable non-stick coating as needed. This coating process involves a release polymer impregnated into a coating that is welded to the base metal of the part. This greatly improves release characteristics of pellets from metal components of the dryer when processing tacky or sticky materials. It allows faster cleaning of dryer surfaces, offers good corrosion resistance and is FDA compliant.

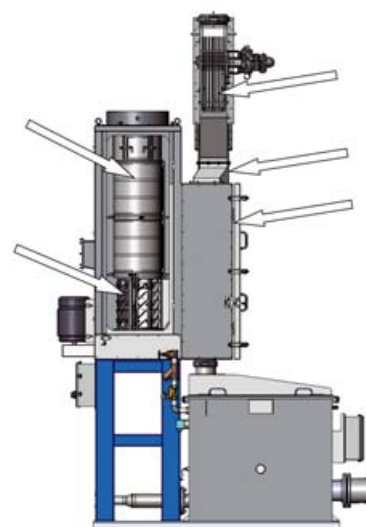

Figure 1

Centrifugal dryers

Technical specifications

Easy Access Dryer

Easy Access Models: The noise level of an Easy Access Dryer is 95 dBA or less at 1 meter processing 3 mm diameter x 3 mm long LDPE pellets and the buyer insulating the pellet outlet and air outlet lines. This can be reduced to 87 dBA or less with optional low-noise modifications. **(Please note that larger and/or harder pellets will adversely affect the noise level.)**



Model 3032DW Easy Access



Model 100 High-Capacity Dryer

Model	Drying Capacity (lbs/hr)	Max. BF (GPM) Water Rate	Max. DW (GPM) Water Rate	Air Flow (CFM)	Motor Size (HP)
1008	500 kg/h (1,100)	12 m ³ /h (50)	N/A	510 Nm ³ /h (300)	2.2 kW (3)
2008	1,200 kg/h (2,600)	20 m ³ /h (90)	N/A	680 Nm ³ /h (400)	4 kW (5)
2016	2,500 kg/h (5,500)	50 m ³ /h (220)	70 m ³ /h (300)	1,700 Nm ³ /h (1,000)	4 kW (5)
3016	6,500 kg/h (14,000)	70 m ³ /h (300)	100 m ³ /h (440)	2,720 Nm ³ /h (1,600)	5.5 kW (7.5)
4016	8,200 kg/h (18,000)	70 m ³ /h (300)	100 m ³ /h (440)	3,400 Nm ³ /h (2,000)	5.5 kW (7.5)
3032	11,500 kg/h (25,000)	45 m ³ /h (200)	180 m ³ /h (800)	5,100 Nm ³ /h (3,000)	7.5 kW (10)
4032	18,500 kg/h (41,000)	45 m ³ /h (200)	340 m ³ /h (1,500)	6,800 Nm ³ /h (4,000)	11 kW (15)
5032	26,000 kg/h (57,000)	45 m ³ /h (200)	340 m ³ /h (1,500)	8,500 Nm ³ /h (5,000)	15 kW (20)
5048	40,000 kg/h (88,000)	90 m ³ /h (400)	685 m ³ /h (3,000)	12,750 Nm ³ /h (7,500)	22 kW (30)
6048	50,000 kg/h (110,000)	90 m ³ /h (400)	685 m ³ /h (3,000)	15,300 Nm ³ /h (9,000)	30 kW (40)
7048	85,000 kg/h (187,000)	90 m ³ /h (400)	910 m ³ /h (4,000)	21,875 Nm ³ /h (12,500)	55 kW (75)

Specifications are subject to change without notice when products are improved in quality or performance.

High-Capacity Dryer

Model	Drying Capacity (lbs/hr)	Max. BF (GPM) Water Rate	Max. DW (GPM) Water Rate	Air Flow (CFM)	Motor Size (HP)
60	60,000 kg/h (130,000)	90 m ³ /h (400)	685 m ³ /h (3,000)	18,700 Nm ³ /h (11,000)	55 kW (75)
70	70,000 kg/h (150,000)	90 m ³ /h (400)	910 m ³ /h (4,000)	18,700 Nm ³ /h (11,000)	55 kW (75)
100	100,000 kg/h (220,000)	90 m ³ /h (400)	1,360 m ³ /h (6,000)	21,875 Nm ³ /h (12,800)	90 kW (120)

Specifications are subject to change without notice when products are improved in quality or performance.

Centrifugal dryers

Technical specifications



Model 3016 ECLN BF



Model 2016 Self-Cleaning

Easy-Clean / Low-Noise Dryer

Easy-Clean / Low-Noise Models: The noise level of an Easy-Clean / Low-Noise Dryer is 80 dBA or less at 1 meter processing 3 mm diameter x 3 mm long LDPE pellets and the buyer insulating the pellet outlet and air outlet lines.

(Please note that larger and/or harder pellets will adversely affect the noise level.)

Model	Drying Capacity (lbs/hr)	Max. BF (GPM) Water Rate	Max. DW (GPM) Water Rate	Air Flow (CFM)	Motor Size (HP)
2008	1,200 kg/h (2,600)	20 m ³ /h (90)	N/A	680 Nm ³ /h (400)	4 kW (5)
2016	2,500 kg/h (5,500)	50 m ³ /h (220)	100 m ³ /h (440)	1,700 Nm ³ /h (1,000)	4 kW (5)
3016	6,500 kg/h (14,000)	70 m ³ /h (300)	135 m ³ /h (600)	2,720 Nm ³ /h (1,600)	5.5 kW (7.5)
32.3	11,500 kg/h (25,000)	70 m ³ /h (300)	290 m ³ /h (1,000)	5,100 Nm ³ /h (3,000)	7.5 kW (10)
32.4	18,500 kg/h (41,000)	70 m ³ /h (300)	230 m ³ /h (1,000)	6,800 Nm ³ /h (4,000)	11 kW (15)
32.5	26,000 kg/h (57,000)	70 m ³ /h (300)	340 m ³ /h (1,500)	8,500 Nm ³ /h (5,000)	15 kW (20)
48.5	40,000 kg/h (88,000)	N/A	685 m ³ /h (3,000)	12,750 Nm ³ /h (7,500)	22 kW (30)
48.6	50,000 kg/h (110,000)	N/A	685 m ³ /h (3,000)	15,300 Nm ³ /h (9,000)	30 kW (40)

Specifications are subject to change without notice when products are improved in quality or performance.

Residual Pellet Moisture: A surface moisture of nil to 0.05% (500 ppm) can be achieved on smooth pellets if the internal pellet heat is 60° C. or above, and the pellets do not contain fines, agglomerates, melt fracture or additives. Gala recommends that the line between the pelletizer and the dryer be as short as practical for maximum pellet heat and minimum outlet moisture. Packaging at the outlet nozzle of a centrifugal pellet dryer is not recommended if low moisture levels are desired. The residence time in a dryer is less than 10 seconds and this time is seldom sufficient to flash-off the residual moisture. If the pellets are hot, residual moisture will flash-off in downstream equipment. Pneumatic conveyors, classifiers and vented storage bins are ideal for flashing-off of residual moisture.

Self-Cleaning Dryer

Model	Drying Capacity (lbs/hr)	Max. BF (GPM) Water Rate	Max. DW (GPM) Water Rate	Air Flow (CFM)	Motor Size (HP)
2008	1,200 kg/h (2,600)	30 m ³ /h (130)	N/A	595 Nm ³ /h (350)	4 kW (5)
2016	2,500 kg/h (5,500)	70 m ³ /h (300)	100 m ³ /h (440)	1,700 Nm ³ /h (1,000)	4 kW (5)

Specifications are subject to change without notice when products are improved in quality or performance.

Centrifugal dryers

Support

**Supported by 24-hour
Service Worldwide!**

Technical Support:

Gala has earned its reputation for providing prompt, dependable service – before, during and after the sale. The mobile phone number of every technician is published on our website so they are available 24 hours a day. Every Customer call is handled with priority.

Training:

Customers are able to order classroom and hands-on training for operators and maintenance personnel on all of our Gala-manufactured equipment, either at the Customer's facility or at Gala's Technical Center..

Technical Centers:

Gala's technical centers are available to Customers who wish to evaluate the suitability of a Gala System for purchase, for assistance in product development, R&D, or for product market sampling.

